



Low Cost and High Performance MMIC Solutions for Automotive Radar

Dr. Markus Behet

© 2009 TriQuint Semiconductor, Inc.



Life is About Connections.

TriQuint 
SEMICONDUCTOR

Connecting the Digital World to the Global Network®

Agenda

- **TriQuint at a Glance**
- The Automotive Radar Market from a GaAs Manufacturers Perspective
- Process Technologies, Assembly Considerations
- Product Development 77 GHz Automotive - Examples
- Summary

“Connecting the Digital World to the Global Network[®]”
Improving the performance and lowering the cost of our customers applications.

What We Do

Connecting the Digital World to the Global Network®

Improving the performance and lowering the cost of our customer's applications

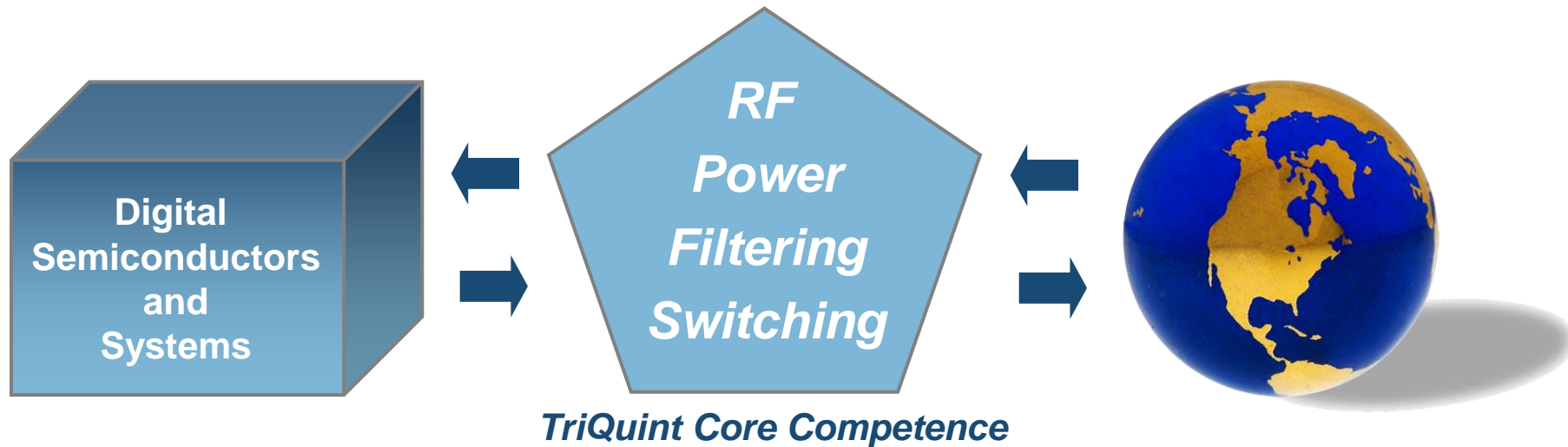

World's largest GaAs foundry

World's third largest GaAs semiconductor supplier

TriQuint – Broadest Technology Portfolio

Higher
Power

GaN, High Voltage pHEMT

Higher
Frequency

mHEMT, Ka-band GaN

Improved
Linearity

Linear pHEMT, HFET, HV HBT

Filtering

SAW, BAW, Wafer Level
Package

Integration

E/D pHEMT, BiHEMT, Passives
Interconnect, Modules

Market Focused Business Units

Handsets

Military

Networks

**Commercial
Foundry**

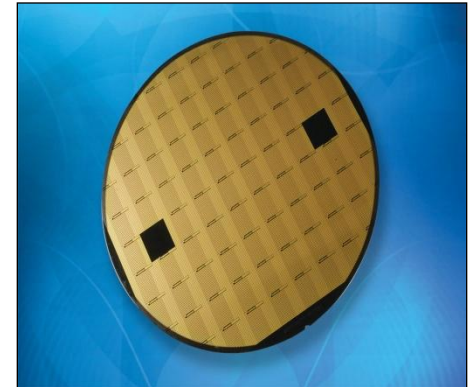

**Volume &
Manufacturing
Efficiency**

**New
Technology
Development**

**Standard
Products**

**Access to
Broader Markets**

Diversified Business Strategy Drives Greater Long Term Profitable Growth

Agenda

- TriQuint at a Glance
- **The Automotive Radar Market from a GaAs Manufacturers Perspective**
- Process Technologies, Assembly Considerations
- Product Development 77 GHz Automotive - Examples
- Summary

“Connecting the digital world to the global network!”
Improving the performance and lowering the cost of our customers applications.

Promising Outlook Before the Economic Crash

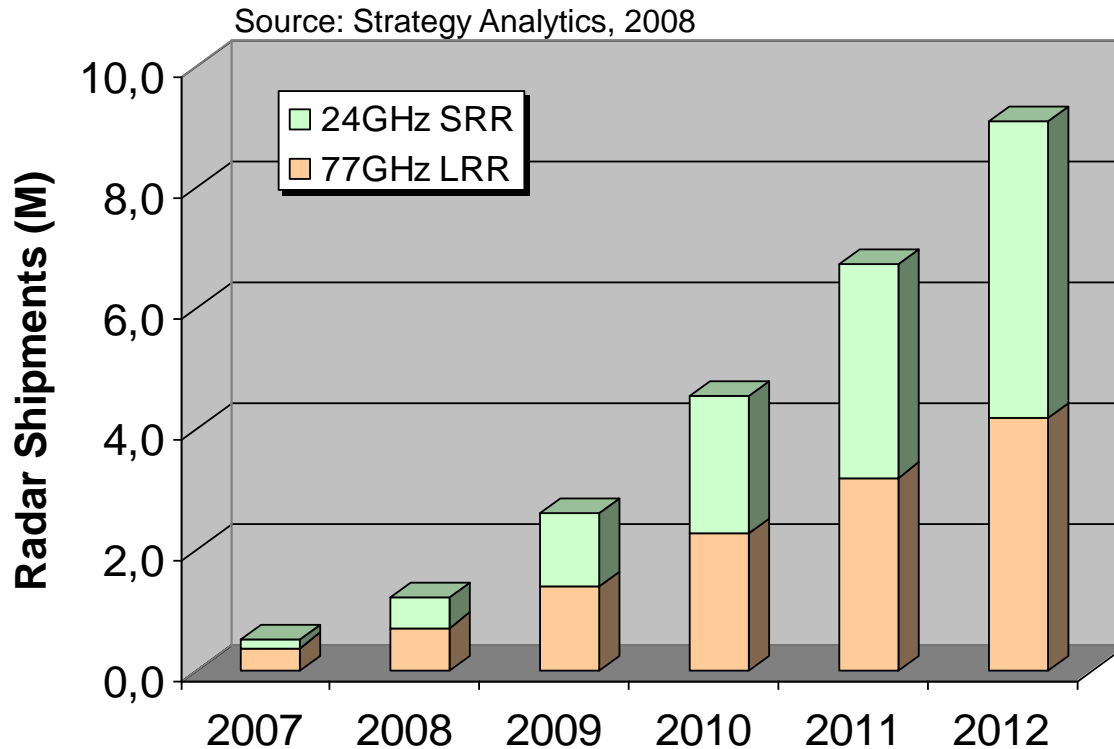

- Semiconductor TAM for 77 GHz Auto Radar in 2008 was approx. \$20M
- Above 77 GHz Radar projections will most likely shift by one year due to the difficult economic environment
- Other Industrial Applications: Level or Proximity Sensing

Characteristics of the 77GHz Radar Market

- No standardization of radar architecture or MMICs
- Trend is that MMIC suppliers partner with system integrators to develop custom MMIC solutions
- Volumes per tier 1 system integrator will range from 50k-250k per year with typical product life times of 5 years: small volumes for GaAs & especially SiGe MMIC suppliers!
- Integration level & price are main application considerations

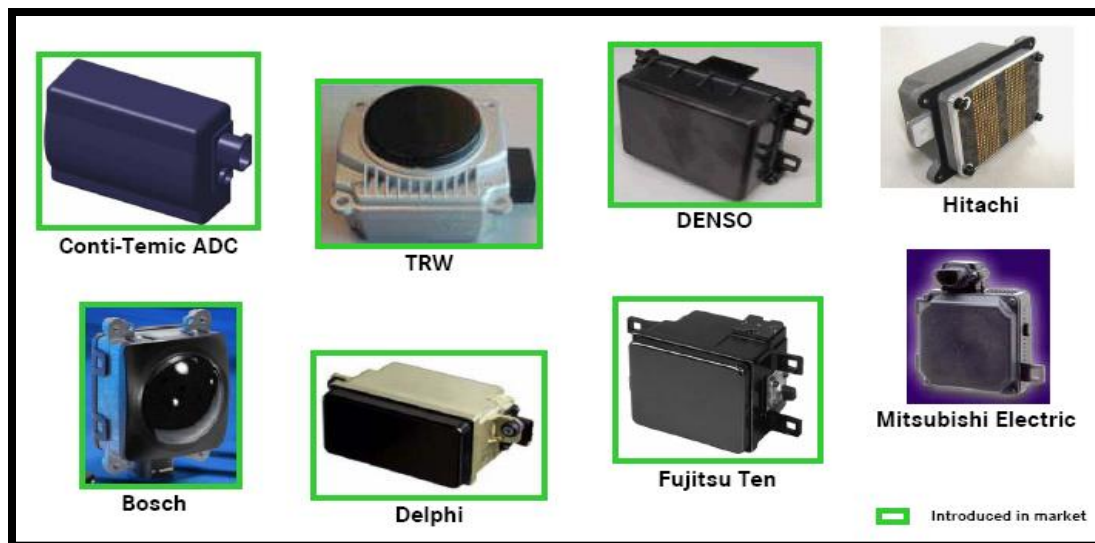

Agenda

- TriQuint at a Glance
- The Automotive Radar Market from a GaAs Manufacturers Perspective
- **Process Technologies, Assembly Considerations**
- Product Development 77 GHz Automotive - Examples
- Summary

“Connecting the digital world to the global network!”
Improving the performance and lowering the cost of our customers applications.

Benefits: Today's GaAs Technologies for 77 GHz Applications

- **Proven Technology**

- Long-standing performance & track record in mmWave technologies for auto radar, defense, satellite & Point-to-Point radio applications

- **Proven Reliability**

- In both high frequency / high reliability environments & commercial products such as handsets & computers

- **Low Development Costs**

- Prototype cost 1/10th that of High Performance Si or SiGe
- Quick Turn times (4 - 6 weeks)

- **Low Production Costs & High Volume Capability**

- Recent developments have enabled mmWave processes on larger substrates & lower-cost processes, namely optical lithography

Device Size and Yield Drives Price

Auto Radar MMICs: It's all about cost!

GaAs designers need to make their designs as compact as possible!

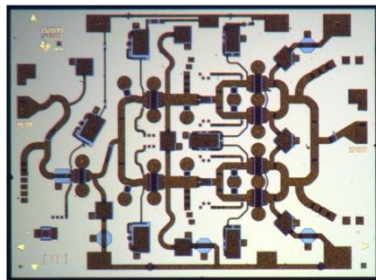

4.1 x 3.0 mm
(12.3 mm²)

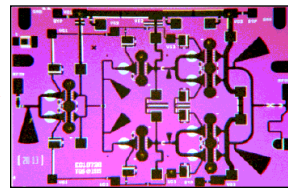

3.12 x 2.16 mm
(6.74 mm²)

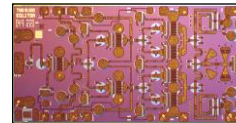

2.69 x 1.37 mm
(3.69 mm²)

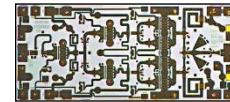

2.436 x 1.154 mm
(2.811 mm²)

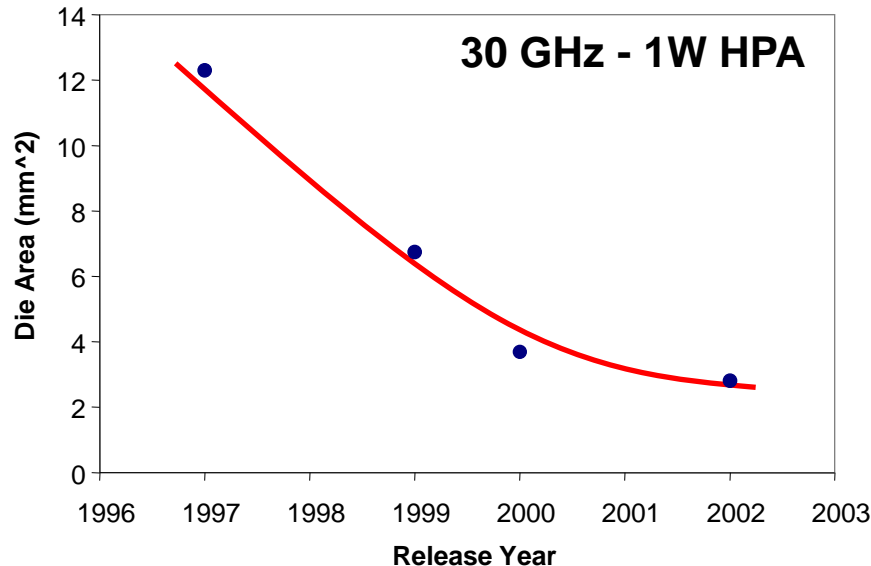

Final size is limited by

- Technology Performance
- Size of Passives
- Gate Finger Spacing
- Output Periphery (Power)
- Number of Stages (Gain)
- Bandwidth

Low Cost mmWave GaAs Process Example

TQP13

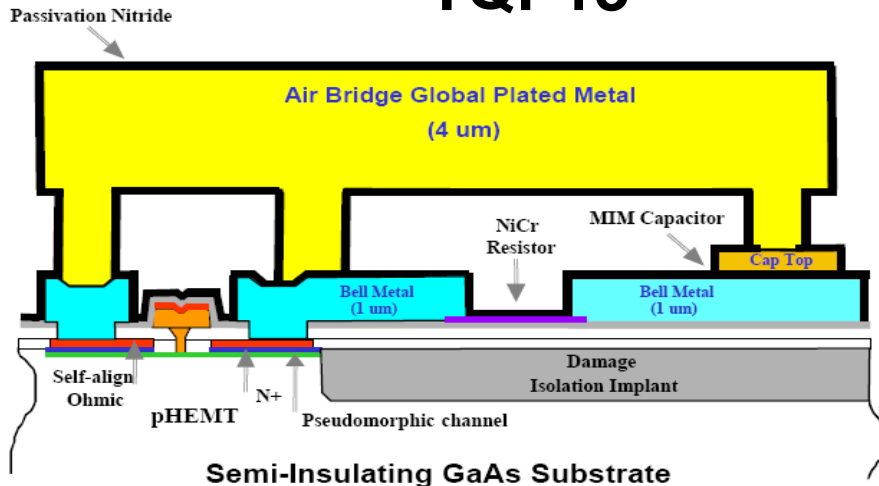

- Already actively used for applications with similar demands:
 - Automotive Radar (up to 77 GHz)
 - 60 GHz WPAN (WiHD)
 - Pt-2-Pt Radio
- Proven up to 110 GHz
- Sufficient power
- Low noise
- High volume / Low cost

0.13 μ m Optical 150mm pHEMT

- 0.13 μ m optical D-mode for low noise
- D-FET: $V_p = -300$ mV
- $F_{max} > 200$ GHz
- $BV_{gd} = 8$ V typical
- $GM = 750$ mS/mm
- $I_{max} = 550$ mA/mm, $I_{dss} = 100$ mA/mm
- $NF < 0.5$ dB (@ 12GHz)
- Metal Interconnects:
 - 1 Local, 1 Global (airbridge)
- Includes 340 pF/ μ m MIM, 50 ohm NiCr Resistors
- 30-50% savings over similar processes that use E-Beam lithography

Flip-Chip Cu-Bump Interconnect Technology

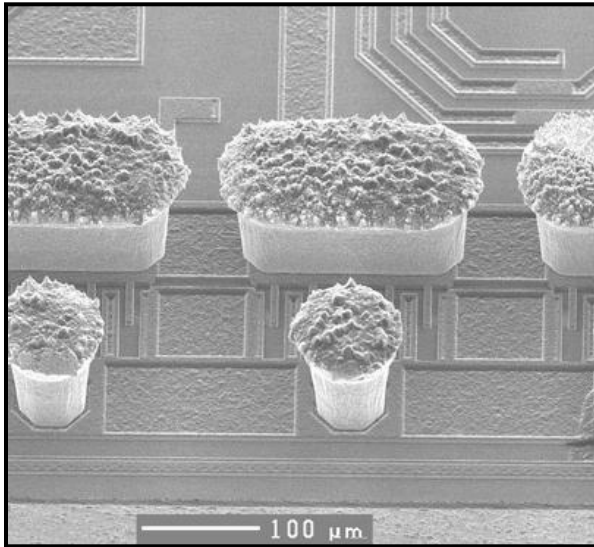

Flip chip

- Lowest inductance connection
- Attachment independent of number of connections
- Potential board and die size reduction
- No backside wafer processing

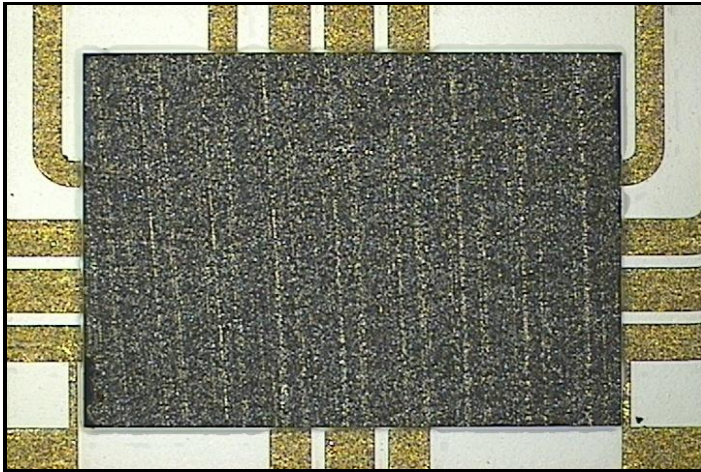

Agenda

- TriQuint at a Glance
- The Automotive Radar Market from a GaAs Manufacturers Perspective
- Process Technologies, Assembly Considerations
- **Product Development 77 GHz Automotive - Examples**
- Summary

“Connecting the digital world to the global network!”
Improving the performance and lowering the cost of our customers applications.

Standard Low Cost 77 GHz GaAs Radar Chipset

TX

19GHz VCO with $\div 8$ 19GHz/38GHz Doubler 38GHz/76.5GHz Doubler/MPA 76.5GHz SP3T

6''- HBT 6''- 0.13 μ m pHEMT 6''- 0.13 μ m pHEMT 4''- VPIN

RX

76.5 GHz I/Q Downconverter 76.5GHz LNA 76.5GHz SP4T

6''- HBT 6''- 0.13 μ m pHEMT 4''- VPIN

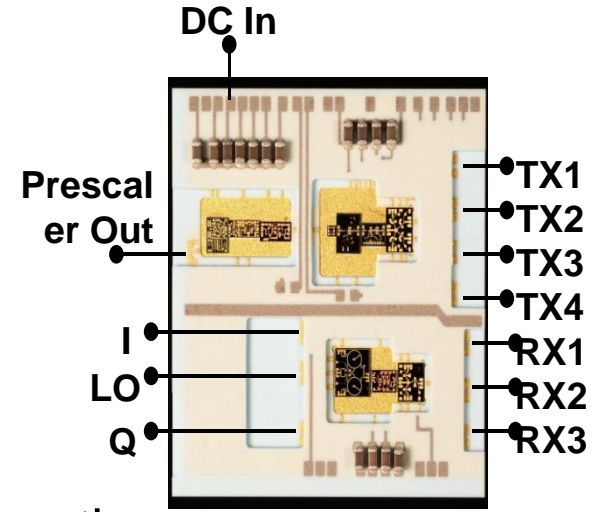

- Optimum process technology was used for each function
- Lead customer is ramping radar using this coplanar chipset in flip-chip configuration

High Integration: Possible with GaAs for 77 GHz Radar Front-end!

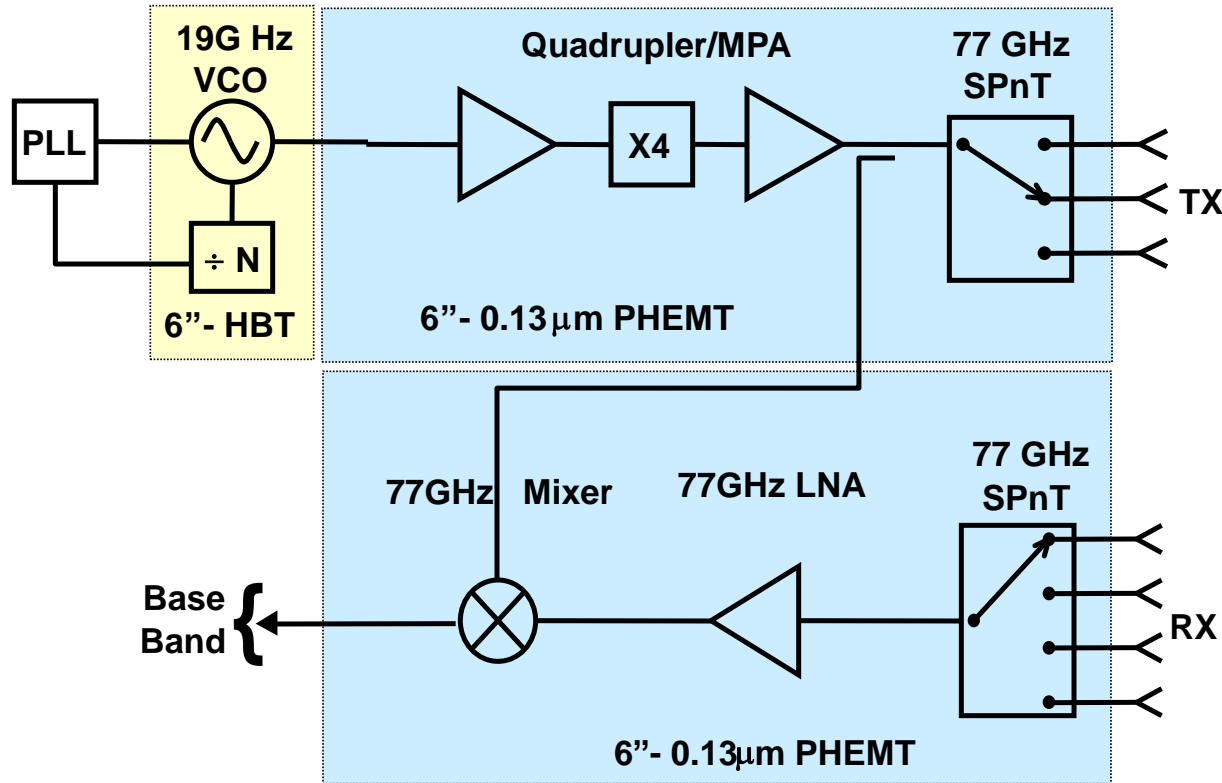

- Only 2 or 3 MMICs on low-cost, 6-inch GaAs processes needed for a complete 77 GHz front end!
- Scalable switch matrix allows more antenna ports for better resolution

Agenda

- TriQuint at a Glance
- The Automotive Radar Market from a GaAs Manufacturers Perspective
- Process Technologies, Assembly Considerations
- Product Development 77 GHz Automotive - Examples
- **Summary**

“Connecting the Digital World to the Global Network[®]”

Improving the performance and lowering the cost of our customers applications.

Summary and TriQuint Value Proposition

- GaAs offers the optimum technologies to serve each auto radar RF function at optimized performance and at minimum cost **AND** GaAs has a track record for 77 GHz radars
- TriQuint has a coplanar 77 GHz MMIC chipset available which is applicable to various front-end architectures
- TriQuint is TS16949 certified and all 77 GHz products are 100% DC/RF on-wafer tested
- TriQuint can develop very price competitive custom MMIC solutions on 6-inch, high-volume GaAs processes for higher integration and provide engineering support for flip-chip integration
- **For Auto Radar details, contact Dr. Markus Behet (markus.behet@tqs.com), or visit these web locations:**
 - **Automotive Applications** on **www.triquint.com**