

On the Necessity of High Performance RF Front-ends in Broadband Wireless Access Employing Multicarrier Modulations (OFDM)

Max Martone*

WJ Communications

Palo Alto, CA 94304-1204, USA

Abstract— Multicarrier systems of the OFDM-type perform a frequency domain decomposition of a channel characterized by frequency selective distortion in a multitude of subchannels that are affected by frequency flat distortion. The distortion in each independent subchannel can then be compensated by simple gain and phase adjustments, somehow overcoming the need of one of the most complex components of a digital modem: the equalizer. On the other hand, coding and transmission power assignments can be applied across the subchannels in a way that resembles the Shannon water pouring argument. As the bandwidth of the subchannels is made sufficiently small one can asymptotically reach the channel capacity. Since this relatively old idea has attracted a significant interest in recent years, we prove that a careful implementation of the analog RF front-end is extremely critical to the asymptotic behavior of multicarrier transmission in approaching capacity. In fact multicarrier signals exhibit extreme vulnerability to distortions induced by RF electronics. We concentrate on the characterization of those degradations that can not be compensated at baseband by means of Digital Signal Processing and show that the throughput achievable by realistic OFDM modems is much lower than what typically advertised, particularly in transceivers with low performance analog RF front-end.

Keywords— Frequency selective channels, Orthogonal Frequency Division Multiplexing (OFDM), Discrete Fourier Transform.

I. INTRODUCTION

A consortium of major players have recently proposed OFDM as a standard modulation scheme for wireless broadband access. The claim is that OFDM will enhance coverage and dramatically reduce cost. These claims are based on two theoretical arguments:

- coding and transmission power assignments in multicarrier systems can be applied across the subchannels in a way that resembles the Shannon water pouring argument (as the bandwidth of the subchannels is made sufficiently small one can asymptotically reach the channel capacity),
- since the transmission over many narrowband subchannels is much easier than the transmission over a wideband channel one can expect a simplification of the baseband processing in the transceiver.

* Email: max.martone@wj.com.

However these arguments assume ideal Radio Frequency characteristics in the analog front-end. This assumption is simply not realistic because multicarrier signals exhibit extreme vulnerability to distortions induced by RF electronics. We discuss in this work the important limitations on the performance of OFDM as they relate to the analog front-end specifications. In particular we focus on those effects that can not be removed at baseband by means of Digital Signal Processing. The method of analysis is based on the loss in mutual information that is consequent to intermodulation distortions, phase noise, transmitter power amplifier nonlinearities. It is important to point out that loss of mutual information causes performance degradation not recovered by coding. The analysis reveals that an accurate RF design is necessary to get *at least a reasonable percentage* of the theoretical maximum achievable rate and, more importantly, that it is debatable the claim that this can be done at consumer level costs.

II. THE IDEAL MULTICARRIER SYSTEM AND ITS ACHIEVABLE DATA RATE

Multicarrier techniques transmit data by dividing the stream into several parallel bit streams. Each of the subchannels has a much lower bit rate and is modulated onto a different carrier. OFDM is a special case of multicarrier modulation with equally spaced subcarriers and overlapping spectra [1]. The OFDM time-domain waveforms are chosen such that mutual orthogonality is ensured in the frequency domain. Time dispersion is easily handled by such systems because the substreams are essentially free of Inter-Symbol Interference (ISI). This last aspect of multicarrier schemes has contributed to increase the popularity of OFDM in many wireless and wire-line applications [2], [3], [4], and has opened a "competition" with more traditional single carrier time-domain schemes. It is important to emphasize that when there is frequency-dispersion Inter-Channel Interference may degrade an OFDM system performance to intolerable levels. The frequency dispersion of an OFDM signal is caused by 1) non-ideal characteristics of the RF electronics, 2) non negligible Doppler Spread. Con-

sider the baseband equivalent signal generated by a generic N -channel multicarrier system expressed as

$$s(t) = \sum_{k=-\infty}^{+\infty} \sum_{l=0}^{N-1} a_{k,l} \phi_{k,l}(t) = \sum_{k=-\infty}^{+\infty} \sum_{l=0}^{N-1} a_{k,l} \phi_l(t - kT), \quad (1)$$

where T is the symbol period and $a_{k,l}$ is the (generally complex valued) information bearing symbol, $\phi_{k,l}(t) = \phi_l(t - kT)$, $l = 0, 1, \dots, N-1$ are the fundamental basis waveforms. In wireless links the transmitted signal $s(t)$ is linearly distorted by the multipath fading channel operator \mathbf{H} as¹

$$\begin{aligned} y(t) &= (\mathbf{H}s)(t) = \sum_{k=-\infty}^{+\infty} \sum_{l=0}^{N-1} a_{k,l} f_{k,l}(t) \\ &= \sum_{k=-\infty}^{+\infty} \sum_{l=0}^{N-1} a_{k,l} f_l(t - kT) \end{aligned} \quad (2)$$

where $f_l(t) = (\mathbf{H}\phi_l)(t)$. The fundamental problem is to select the transmission basis $\phi_l(t)$ in such a way that the projection of the signal onto an identically structured signal set $f_{k,l}(t)$ gives the transmitted symbols as

$$\int_{-\infty}^{+\infty} y(t) f_{k,l}^*(t) dt = \int_{-\infty}^{+\infty} y(t) f_l^*(t - kT) dt = a_{k,l}.$$

This condition implies relative simplicity of the receiver and robustness to additive white Gaussian noise. The selection of a channel-dependent signal basis in the case of a static channel $(\mathbf{H}s)(t) = \int h(\tau)s(t - \tau)d\tau$ is well-understood and corresponds to functions $\phi_l(t)$ equal the eigenmodes of the channel autocorrelation. The eigenmodes of a frequency selective static channel can be well approximated by Fourier bases and transmitter and receiver easily implemented by means of Fourier Transform methods. The popularity of OFDM schemes stems exactly from this fundamental property. It is however important to realize that if the channel is doubly dispersive, as in the rapidly fading wireless channel, the entire conceptual framework of the basic Fourier-domain channel partitioning scheme loses its optimality, even in an ideal receiver. Consider the baseband representation of a multicarrier system as in (1) with

$$\phi_{k,l}(t) = g(t - kT)e^{j2\pi lFt}, \quad (3)$$

where F is the carrier frequency spacing and $g(t)$ is a shaping window. The use of pulses as in (3) results in a rectangular *tiling* of the time-frequency plane. The product $TF \geq$

¹The operator \mathbf{H} represent the effects of multipath RF waves propagation. One standard way of representing the channel is

$$(\mathbf{H}s)(t) = \int_{-\infty}^{+\infty} \int_{-\infty}^{+\infty} S(\tau, \nu)s(t - \tau)e^{j2\pi\nu t} d\tau d\nu$$

where $S(\tau, \nu)$ is the spreading function of the wireless channel.

1 defines the time-frequency product of each independent function in the signal set. In the OFDM case the pulse $g(t)$ in (3) is a rectangular window of duration T and $F = 1/T$. A *coarsification* of the time-frequency grid is typically employed using a guard-time between temporal adjacent symbols for mitigation of the time-dispersive characteristic of a frequency selective channel. On the other hand properly shaping the basic symbols in each subchannel by using a pulse different from the rectangular one mitigates frequency dispersion effects of the channel caused by Doppler spreads. However if the channel is perfectly static with Fourier Transform $H(f)$, and the guard-time is long enough to cover for the support of the channel one can use (3) at the transmitter and select matched filters at the receiver of the form $f_{k,l}(t) = \frac{1}{[H(lF)]} e^{j\arg[H(lF)]} g(t - kT)e^{j2\pi lFt}$. In practice these matched filter operations are implemented by DFT-based transformations and a bank of single tap equalizers. Including now the effect of additive Gaussian noise we have the equivalent discrete-time system

$$\begin{aligned} z_{k,l} &= \int_{-\infty}^{+\infty} y(t)g(t - kT)e^{-j2\pi lFt} dt \\ &= H(lF)a_{k,l} + n_{k,l} \end{aligned} \quad (4)$$

for $l = 0, 2, \dots, N-1$ and $k = -\infty, \dots, 0, \dots, +\infty$. At any given k arranging N samples in N -vectors gives

$$\mathbf{z}(k) = \Lambda_H \mathbf{a}(k) + \mathbf{n}(k) \quad (5)$$

where Λ_H is a diagonal matrix with generic l th diagonal element $H(lF)$, and the organization of $z_{k,l}$, $a_{k,l}$ and $n_{k,l}$ in the vectors $\mathbf{z}(k)$, $\mathbf{a}(k)$, $\mathbf{n}(k)$ respectively should be clear from the context. The modeling assumptions we have described can be summarized as in Fig. 1.

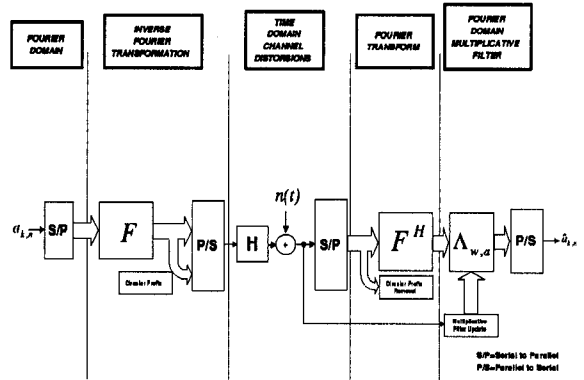

Fig. 1. Functional block diagram of the baseband signal processing of an OFDM system that employs IFFT/FFT. The transformation F is the basic DFT matrix.

III. THE CHARACTERIZATION OF RF DISTORSIONS

The Carrier to Noise ratio (CNR) at the RF front-end output is probably the most important indicator of the ca-

pability of the receiver to properly demodulate the signal. Given a particular modulation scheme we typically want to achieve some quality of service (QOS) specified by a target Bit Error Rate (BER). In turn the BER will specify the Carrier to Noise Ratio required to achieve in an ideal AWGN (Additive White Gaussian Noise) environment such a QOS. The usual simplifying assumption is that distortions can be treated as noise in terms of signal quality degradation. The CNR γ is defined as

$$\gamma = \left[\frac{1}{10^{-0.1\gamma_{NF}} + 10^{-0.1\gamma_{PN}} + 10^{-0.1\gamma_{IM}} + 10^{-0.1\gamma_{PA}}} \right]_{dB}$$

where

1. γ_{IM} is the signal to interference ratio caused by intermodulation distortions,
2. γ_{NF} is the signal to noise ratio caused by the Noise Figure of the receiver,
3. γ_{PN} is the signal to interference ratio caused by phase noise distortion,
4. γ_{PA} is the signal to interference ratio caused by nonlinearities in the Power Amplifier at the transmitter.

Roughly speaking, at low input level γ depends on the noise figure F of the receiver as

$$\gamma_{NF} = 10 \log_{10} \left[\frac{P_i}{KTBF} \right]$$

where K is the Boltzmann constant, F is the noise figure in antilogarithm, T is the absolute temperature, B is the system bandwidth. Since we typically want an SNR per symbol (that is SNR over the Nyquist bandwidth) greater than some target SNR, say γ , we need $\gamma_{IM} \gg \gamma_{NF}$ and $\gamma_{PN} \gg \gamma_{NF}$, if we want $\gamma_{NF} \simeq \gamma$. For example we may say $\gamma_{IM} \geq \gamma_{NF} + 10dB$ and $\gamma_{PN} \geq \gamma_{NF} + 10dB$. The intermodulation (IM) products that are typically of concern are third-order ones. A well-known testing procedure is a two tone test in which one excites the receiver with two sinusoids with equal power and the resulting output power at the third-order IM components are measured. In a two-tone test, γ_{IM} is given by the power at the input to the receiver minus the power at the third order IM component at the output of the receiver, $\gamma_{IM3}^{(2)} = P_i - P_{IM}$. In a multicarrier system with N carriers the two tones are divided in N subcarriers each one with power $P_i - 10 \log_{10} N/2$ so that the average power of the third order IM products created by the two-tone subcarriers is $P_{IM} - 30 \log_{10} N/2$. Of course one has to find out how many IM products (say M) fall in a certain subcarrier position. It turns out that the center subcarrier (which is also the position of the RF carrier) is the subcarrier that will experience the worst IM interference. So we can assume that the signal to IM distortion ratio of the receiver is the worst case one and write

$$\gamma_{IM} = P_i - 10 \log_{10} N/2$$

$$\begin{aligned} & - (P_{IM} - 30 \log_{10} N/2 + 10 \log_{10} M) \\ & = \gamma_{IM3}^{(2)} + 20 \log_{10} N/2 - 10 \log_{10} M. \end{aligned} \quad (6)$$

The effect of phase noise and/or frequency offset is represented by the matrix

$$\mathbf{R}(t) = \begin{bmatrix} \cos(\theta(t)) & -\sin(\theta(t)) \\ \sin(\theta(t)) & \cos(\theta(t)) \end{bmatrix}$$

where $\theta(t)$ is the instantaneous difference in phase between the phase of the oscillator at the transmitter and at the receiver. The overall model is given by $\mathbf{v}_d(t) = \mathbf{R}(t)\mathbf{s}(t) + \mathbf{n}(t)$. The signal $\tilde{s}(t)$ is distorted as $\tilde{s}(t)e^{j\theta(t)}$. Of course the non-ideal characteristics of the RF hardware destroy the orthogonality of the carriers in an OFDM system and contribute to an intercarrier interference effect that can be approximately quantified at the input to the slicer for the i th carrier ($0 \leq i \leq N-1$) and for the n th block of symbols as

$$z_{n,i} = a_{n,i}d_0 + \sum_{\substack{k=0 \\ k \neq i}}^{N-1} a_{n,i}d_{i-k} + \eta_{n,i}$$

where

$$\begin{aligned} d_k &= \frac{1}{T} \int_0^T e^{j(\theta(t) - 2\pi \frac{kt}{T})} dt \\ &= \frac{1}{N} \sum_{n=0}^{N-1} e^{j(\theta(nT_s) - 2\pi \frac{kn}{N})} = \frac{1}{T} \Psi_k. \end{aligned} \quad (7)$$

The effect of a noisy phase reference introduced by LOs' phase noise creates two types of distortions: 1) Common Phase error (CPE), (represented by d_0), 2) Inter-Channel Error (ICE), (represented by $d_k, k \neq 0$). The effect of ICE on γ_{PN} is several orders of magnitudes more detrimental than the effect of CPE in part because the effect of CPE can be compensated at baseband (in the DSP processors) by amplitude and phase adjustments. For this reason we can write for the l th subcarrier (and with a subcarrier spacing f_s)

$$\gamma_{PN} = - \left[\sum_{k \neq l} \int_{-\infty}^{+\infty} w^2(f/f_s) |\Phi(f - (k-l)f_s)|^2 df \right]_{dB} \quad (8)$$

where $w(x)$ is a $\frac{\sin(x)}{x}$ weighting function, $|\Phi(f)|^2$ is the phase noise power density. Nonlinear distortions in an OFDM system are essentially due to the transmitter (high) power amplifier (HPA) which is typically driven close to saturation for power efficient transmission. The nonlinear effects on the transmitted signals are 1) spectral spreading, 2) intermodulation effects on the subcarriers, 3) warping of the signal constellation in each subchannel. The input/output relation on the complex baseband signal for a power amplifier is $s_u(t) = \mathcal{G}(\tilde{s}(t))$ with $\mathcal{G}(\tilde{s}(t)) =$

$\mathcal{A}[\tilde{s}(t)] e^{j\Psi[\tilde{s}(t)]}/|\tilde{s}(t)|$. The functions $\mathcal{A}[\cdot]$ and $\Psi[\cdot]$ characterize the AM/PM conversions in the HPA, respectively. For a Solid State Power Amplifier a common model is

$$\mathcal{A}[r] = \frac{\nu r}{[1 + (\nu r/A_0)^{2p}]^{1/2p}} \quad \Psi[r] \simeq 0$$

where $A_0 = \nu A_s$ is the saturating amplitude, ν is the small-signal gain and p is an integer. A_s is typically equal to $\frac{1}{\sqrt{0.25}}$. Nonlinear distortions depend on the input backoff IBO or the output backoff OBO

$$IBO = 10 \log_{10} \frac{A_s^2}{\langle P_{IN} \rangle}, \quad OBO = 10 \log_{10} \frac{A_s^2}{\langle P_{OUT} \rangle}.$$

An OFDM signal (for large number of carriers) is accurately modeled as a bandlimited zero mean Gaussian random process. It is then possible to obtain the correlation properties of the process at the output of the HPA and to determine spectral spreading. Following [7] we can characterize the distortions (seen at the receiver, l th carrier, k th OFDM symbol) due to power amplification at the transmitter as

$$z_{k,l} = \alpha H(lF) a_{k,l} + n_{k,l} + \eta_{k,l}$$

where

$$\alpha = R_{s_u}^*(0)/R_{\tilde{s}}(0)$$

with $R_{s_u}(\tau) = E\{s_u(t+\tau)s_u(t)^*\}$ and $R_{\tilde{s}}(\tau) = E\{\tilde{s}(t+\tau)\tilde{s}(t)^*\}$ as derived in [7]. The multiplicative term α can be (optimistically speaking) removed at baseband. The additive term $\eta_{k,l}$ is a Gaussian term whose in phase and in quadrature variances are given by

$$\sigma_{I,\eta_{k,l}}^2 = \sigma_{Q,\eta_{k,l}}^2 = \frac{\mathcal{F}[R_{s_u}(\tau)](0) + \mathcal{F}[R_{\tilde{s}}(\tau)](0)}{2|\alpha|^2},$$

where $\mathcal{F}[x(t)](f)$ is the Fourier transform of a generic signal $x(t)$. Evidently γ_{PA} is the ratio of the signal power to $\sigma_{I,\eta_{k,l}}^2 + \sigma_{Q,\eta_{k,l}}^2$.

It should be clear that any deviation in the system from the ideal system model (5) will give some loss of achievable information throughput essentially due to error rate increase. We want to quantify such loss, for typically specified RF front-ends. Capacity is the maximum achievable rate on a certain channel given unlimited complexity in the channel coding scheme and optimal digital signal processing at the receiver. The capacity of the static frequency selective multi-path channel with frequency domain response $H(f)$ is given by

$$C = \int_B \log_2 \left[1 + P_s^{(o)}(f) \frac{|H(f)|^2}{N(f)} \right] df \text{ bit/sec}$$

where $P_s^{(o)}(f)$ is the optimum ² power spectral density of the transmitted signal $s(t)$, $N(f)$ is the power spectral density of the additive channel Gaussian noise. Multicarrier Transmission with N subcarriers is supposed to asymptotically approach C as subcarrier spacing $B/N = \Delta f$ decreases and N increases. In fact assuming that $P_s^{(o)}(f)$ and $\frac{|H(f)|^2}{N(f)}$ are almost flat within Δf , The capacity of the generic i th subchannel is

$$C_i = \Delta f \log_2 \left[1 + P_s^{(o)}(f_i) \frac{|H(f_i)|^2}{N(f_i)} \right],$$

so that the aggregate rate is $\sum_{i=1}^N C_i$. The capacity of the discrete-time model in (5) in *bit/sec* is

$$\begin{aligned} C_N &= \Delta f \sum_{n=1}^N \log_2 \left[1 + \sigma_{a,n}^{2,(o)} \frac{\lambda_n}{\sigma_n^2} \right] \\ &= \Delta f \sum_{n=1}^N \log_2 \left[1 + \frac{\lambda_n}{10^{-0.1 SNR_{NF}^{(o)}(n)}} \right] \\ &\simeq \sum_i C_i \Rightarrow C, \text{ as } N \rightarrow \infty \end{aligned} \quad (9)$$

where $\sigma_{a,n}^{2,(o)}$ and σ_n^2 are the variances of the elements of the vectors $\mathbf{a}(k)$ and $\mathbf{n}(k)$, respectively, while $SNR_{NF}^{(o)}(n)$ is the SNR of the OFDM signal in the n th carrier. The superscript ^(o) is indicating that the power assigned to the particular subcarrier obeys the water-filling solution. The basic approach that will allow us to assess a decrease in achievable throughput due to the RF front-end, is to consider the equivalent loss in Carrier to Noise Ratio caused by: Noise Figure of the receiver, Intermodulation distortions, Transmitter Power Amplifier. Phase distortions effects are analyzed in terms of the actual signal phase distortions.

From the previous Section we can say that the model (5) becomes in practice

$$\mathbf{z}(k) = \Lambda_H \Phi \mathbf{a}(k) + \mathbf{n}(k) + \mathbf{n}_{IM}(n) + \mathbf{n}_{PA}(n).$$

where $\mathbf{n}(n)$ is the thermal noise term already accounted for in (5), $\mathbf{n}_{IM}(n)$ is the vector representation of the distortions caused by third order intermodulation products, $\mathbf{n}_{PA}(n)$ is the vector representation of the distortions caused by nonlinearities in the Power Amplifiers at the transmitter and $[\Phi]_{m,l} = d_{m-l}$. Assuming all these noise

² $P_s^{(o)}(f)$ satisfies

$$P_s^{(o)}(f) = \begin{cases} K - \frac{N(f)}{|H(f)|^2} & f \in B \\ 0 & \text{elsewhere} \end{cases}$$

where $B = \{f : P_s^{(o)}(f) > 0\}$ is called the capacity achieving band and K is a constant chosen such that a power constraint is satisfied $\int |s(t)|^2 dt \leq P$.

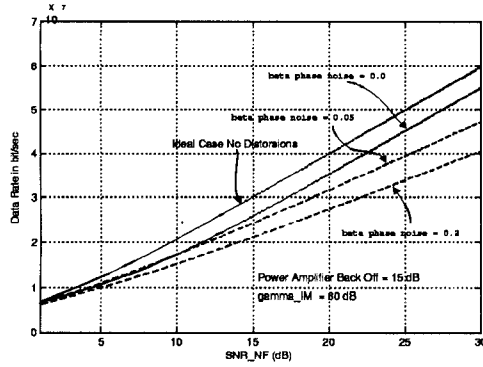

Fig. 2. Achievable data rate for a typical system: the effect of phase noise is expressed by β .

sources to be Gaussian, independent and approximately white (or sufficiently flat across the bandwidth of the receiver), one can easily show that the achievable data rate is

$$\bar{R} = \Delta f \sum_{n=1}^N \int_{\Phi} \log_2 \left[1 + \left(\frac{|\lambda_{\Phi,n}|^2}{10^{-0.1\gamma_{NF}^{(\sigma)}} + 10^{-0.1\gamma_{IM}^{(\sigma)}} + 10^{-0.1\gamma_{PA}^{(\sigma)}}} \right) \right] \times p_{\Phi}(\Phi) d\Phi \quad (10)$$

where $\lambda_{\Phi,n}$ are the singular values of the matrix $\Lambda_H \Phi$, and $p_{\Phi}(\Phi)$ is the probability density function of the elements of the matrix Φ for a given assumed distribution of the phase noise. For example the elements of Φ can be considered Wiener-Levy processes (or continuous path Brownian motion) with variance $2\pi\beta|t|$, [6].

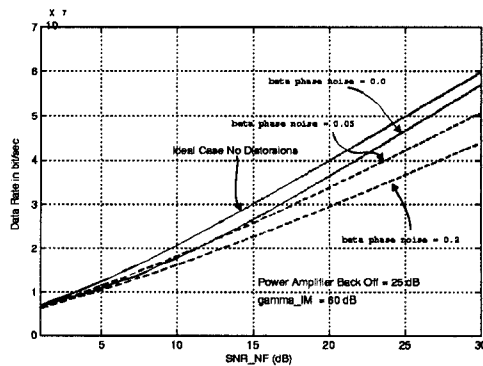

Fig. 3. Achievable data rate for a typical system: influence of increased power amplifier back-off.

We show some numerical results for a typical multicarrier system. The fading channel is static (for a fixed wireless

application) and the main system specifications are as follows.

- Carrier frequency: 2.5GHz
- Input Level: -10:80 dBm
- Bandwidth: 6 MHz
- DMT Symbol duration (N) is 512, cyclic prefix length is 15,
- Multipath maximum Delay Spread: 2 μ sec,
- Third Order Intermodulation: up to 62 dB, measured with -10dBm 2-tones,
- 1 dB compression point: 20 dBm,
- Target Output CNR=20 dB at -80dBm (assume convolutionally encoded 64-QAM),
- Phase Noise
 - Variable up to -65dBc/Hz at 1KHz offset,
 - Variable up to -90dBc/Hz at 10KHz offset,

Fig. 2-3 show performance for an amplifier Input Back Off of 15 and 25 dB, and two different cases of intermodulation distortions. The variance of the Wiener phase process which characterizes phase noise is $\beta_T = 2\pi\beta T$.

IV. CONCLUSIONS

The popularity of the OFDM scheme should be revisited in light of practical RF implementation issues. The multicarrier signal is significantly more vulnerable than single carrier schemes to nonideal characteristics of the RF front-end and it is extremely important to perform proper RF subsystem design to ensure adequate data throughput across the network. Realistic distortions in phase and amplitude and phase noise may degrade the performance of the demodulator to intolerable levels. This inherent fragility of the OFDM signal is in sharp contrast with the common belief that transmission of a signal over multiple orthogonal carriers increases the robustness of a high data rate link.

REFERENCES

- [1] R.W. Chang, "Orthogonal Frequency Division Multiplexing", *U.S. Patent* 3,488,445, filed 1966, issued Jan. 6, 1970.
- [2] L. J. Cimini, "Analysis and simulation of a digital mobile channel using orthogonal frequency division multiplexing", *IEEE Trans. Comm.*, vol. 33, pp. 665-675, Jul. 1985.
- [3] B. Hirotsaki, "An orthogonally multiplexed QAM system using the discrete Fourier transform", *IEEE Trans. Comm.*, vol. 29, pp. 982-989, Jul. 1981.
- [4] J. S. Chow, J. C. Tu and J. M. Cioffi, "A discrete multitone transceiver system for HDSL application", *IEEE J. Sel. Areas Comm.*, vol. 9, n. 6, pp. 895-908, Aug. 1991.
- [5] G. J. Foschini and J. Salz, "Digital communications over fading radio channels," *Bell Syst. Tech. J.*, vol. 62, pp. 429-456, Feb. 1983.
- [6] L. Tomba, "On the Effect of Wiener Phase Noise in OFDM Systems" *IEEE Transactions on Communications*, Volume 46 Number 5, May 1998.
- [7] E. Costa, M. Midrio, and S. Pupolin, "Impact of Amplifier Non-linearities on OFDM Transmission System Performance" *IEEE Communications Letters*, Vol. 3 N. 2, February 1999.