

High Efficiency WCDMA Envelope Tracking Base-Station Amplifier Implemented with GaAs HVHBTs

Donald Kimball, Myoungbo Kwak, Paul Draxler, Jinseong Jeong, Chin Hsia, Craig Steinbeiser, Thomas Landon, Oleh Krutko, Larry Larson, Peter Asbeck

Abstract—A high-performance GaAs HVHBT WCDMA/WiMAX base-station power amplifier is presented, which uses an envelope tracking bias system to achieve high linearity and efficiency. The measured overall power-added efficiency (PAE) reached 58%, with a normalized power RMS error of 2.9% and ACLR1 of -49dBc with digital predistortion (DPD), at an average output power of 42W and gain of 10.2dB for a single carrier WCDMA signal at 6.6dB PAR. To the authors' knowledge, this corresponds to the best efficiency reported for a single stage WCDMA base-station power amplifier. For 7.7dB PAR single carrier WCDMA overall PAE reached 55%, with a normalized power RMS error of 2.9% and ACLR1 of -48dBc with DPD, at an average output power of 33W and gain of 10.2dB. DPD was used at two levels: memoryless DPD to compensate for the expected gain variation of the amplifier over the bias envelope trajectory, and deterministic memory mitigation, to further improve the linearity. DPD with memory mitigation resulted in -70dBc ACLR1&2 and 0.3% RMS error, resulting in a best reported linearization improvement result. For 10MHz WiMAX at 8.8dB PAR overall PAE reached 48%, with an ACLR1 of -41dBc with DPD, at an average output power of 25W and gain of 10.4dB.

Index Terms— Base-station power amplifier, efficiency, envelope tracking, digital predistortion, WCDMA, WiMAX, GaAs HVHBT

I. INTRODUCTION

High power-added efficiency is an important objective for base-station amplifiers, improving thermal management, reliability, and lowering cost. It is challenging to maintain high efficiency during operation over the wide instantaneous power range required for modern communication signals such as WCDMA, while maintaining tight error vector magnitude (EVM) and ACLR specifications. Si-LDMOS has been a popular transistor choice for base-station high power amplifiers, since LDMOS technology can provide reliable and cost effective solutions [1]. However, in order to obtain better linearity and efficiency for 3G wireless base-stations, intense research on high voltage GaAs HVHBTs[2] and FETs[3], and GaN HFETs[4][5] has been carried out. GaAs HVHBTs are attractive options since they can provide both high voltage and high efficiency and gain over wide dynamic range signals.

Recently, high performance GaAs HVHBTs have been

Manuscript received May 12, 2008. This work was supported in part by TriQuint and the University of California San Diego.

D. Kimball, J. Jeong, C. Hsia, P. Draxler, M. Kwak, L. Larson, and P. Asbeck are with University of California, San Diego, CA 92092 USA (phone : 858-534-8225; fax:858-534-0556; e-mail: dfkimball@ucsd.edu).

P. Draxler is also with QUALCOMM, Inc. (email: pdraxler@ieee.org)

C. Steinbeiser, T. Landon, and O. Krutko are with TriQuint Semiconductor, Inc., Richardson, TX. 75080 (phone: 972-994-4534) email <steinbeiser@tqs.com>

reported showing 250 W output peak power and 57% collector efficiency (53% PAE) at 6.5dB PAR for WCDMA base-stations in Doherty configurations [6]. In this work, GaAs HVHBTs were used in a WCDMA base-station amplifier, in which high efficiency was achieved by using an envelope tracking technique on the collector bias. The envelope tracking architecture employs a dynamic supply voltage that tracks the input RF envelope for efficiency enhancement. In the system, shown schematically in Fig. 1, the dynamic supply voltage is provided by a high efficiency wideband envelope amplifier. Measurements reported here show that the overall system exceeds the linearity requirements for WCDMA and WiMAX and achieves record overall efficiency (accounting for power dissipated by both the RF amplifier and the envelope amplifier). The efficiency attained in the envelope tracking amplifier is dramatically better than that obtained with constant collector voltage, because 1) the amplifier operates closer to saturation, 2) the transistor temperature is maintained at a lower value, and 3) the dynamic peak voltage reaches higher values than can be used for constant collector bias voltages.

II. GaAs HVHBT-BASED RF AMPLIFIER

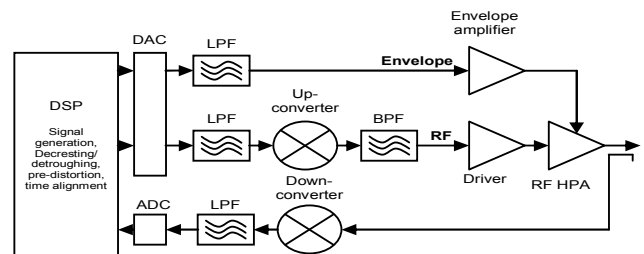

Figure. 1. Block diagram of envelope tracking base-station amplifier

Transistor devices in this work are fabricated using TriQuint's InGaP/GaAs High-Voltage Heterojunction Bipolar Transistor (HVHBT) process. Figure 2 shows a top view of a single-ended HVHBT device and package that achieves 100Wcw (50dBm) at P1dB.

The packaged device consists of two HVHBTs combined in a CuW-ceramic package. Pre-match circuits within the package provide an impedance of $2 - j1.7$ ohm at 2.14 GHz at the output and $2.7 - j0.2$ at the input. The HBT was biased in class AB mode. Impedance matching via microstrip lines and 2nd harmonic traps was used on input and output as shown in Fig 3 [10]. No higher harmonic terminations were explicitly provided. The implemented RF power amplifier shows 130W(51.2dBm) peak under CW operation at 2.14 GHz. The measured performance with fixed DC collector bias of 28Vdc and quiescent current of $I_{qc}=400$ mA with 1xWCDMA at

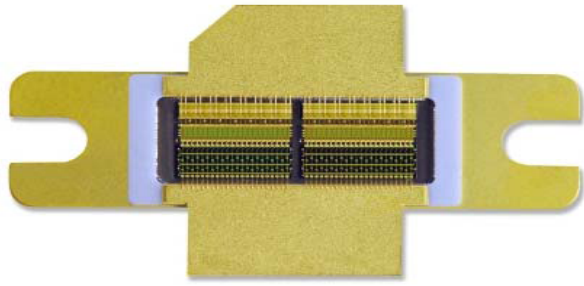

Figure 2. Photograph of HVHBT Module that exhibits 100W (50dBm) at P1dB. Base (bottom lead) Collector (top chamfered lead) and Emitter (flange).

PAR=7.5dB was $P_o=44\text{dBm}(25\text{W})$, CE=35%, ACLR1=38dBc without DPD and 60dBc with DPD with Gain=14.5dB measured at 2140MHz.

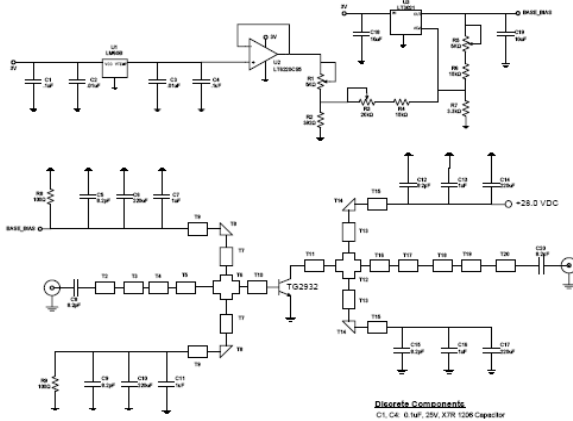

Figure 3: Circuit diagram of Class AB RF amplifier output stage.

III. WIDEBAND HIGH EFFICIENCY ENVELOPE AMPLIFIER

The envelope amplifier used in this work, shown schematically in Fig. 4, comprises a linear stage to provide a wideband voltage source and, in parallel, a switching stage to provide an efficient current supply. The output voltage of the envelope amplifier follows the input envelope signal with help of an operational amplifier. The current is supplied to the RF amplifier collector from both the linear stage and the switching stage through a current feedback network which senses the current flowing out of the linear stages and turns on/off the switch [8]. The linear stage provides the difference between the desired output current and the current provided by the switching stage, such that the overall error is minimized.

Measurement of the high voltage envelope amplifier used in this work shows efficiency of approximately 71% under WCDMA and WiMAX signals. At full output power, the peak output voltage was 29 V and the RMS (root-mean-square) voltage was 12.8 V.

IV. PREDISTORTION SYSTEM

The WCDMA signal is generated in the digital domain, and consists of an envelope signal, as well as I and Q RF signals. After up-conversion, the resultant RF signal provides the input to the RF amplifier, whose supply voltage is modulated by the amplified envelope signal by the wide band and high efficiency envelope amplifier. To minimize distortion by the time delay difference between the Vdd envelope and RF path, synchronization is performed by comparing the input and down-converted output signal [7]. A memoryless predistortion (DPD) is also carried out in the digital domain in order to minimize the AM-AM and AM-PM distortion caused by the RF amplifier and envelope amplifier. Decreasing (an adjustment of the peak-to-average ratio), is performed digitally on the envelope of the signal to optimize the efficiency, ACLR and EVM performance. To avoid gain collapse of the RF amplifier at low collector voltages, the envelope of the signal is also detroughed (adjustment is made to the envelope signal in the vicinity of its zeros). A second level memory mitigation DPD is performed that compensates for a perturbation to the instantaneous gain caused by deterministic memory effects [9].

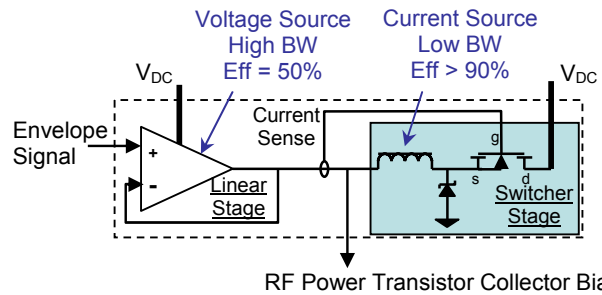

Figure 4: Schematic diagram of high efficiency envelope amplifier.

V. Measurement Results

The overall envelope tracking amplifier was measured with single carrier WCDMA signals with 3.84 MHz bandwidth. The peak-to-average power ratio of the signals is 7.7dB unless stated otherwise.

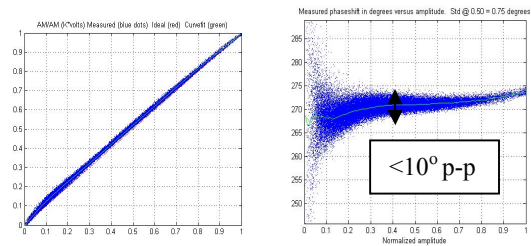

Figure 5. Left, measured AM-AM distortion, Right, AM-PM distortion bottom, before predistortion, x-axis: normalized input amplitude on a linear scale

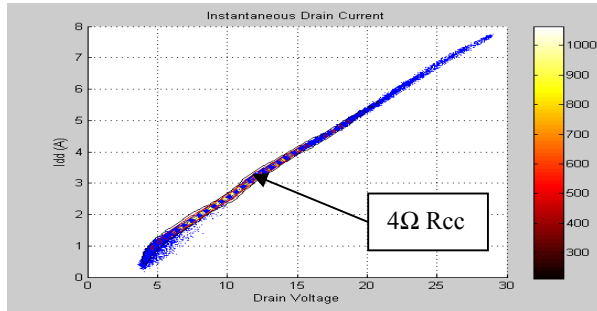

Figure 6: Dynamic collector load line, drain voltage vs collector current, 4Ω resistive 7V to 29Vmax

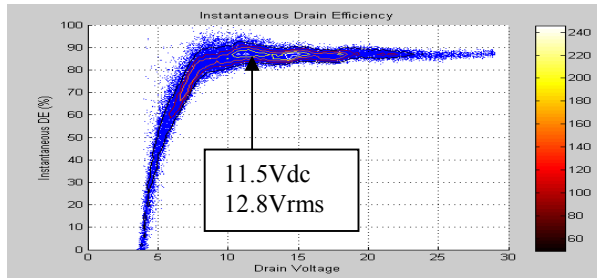

Figure 7. Measured Dynamic Collector Voltage vs Instantaneous Collector Efficiency, 85% 7V to 29Vmax

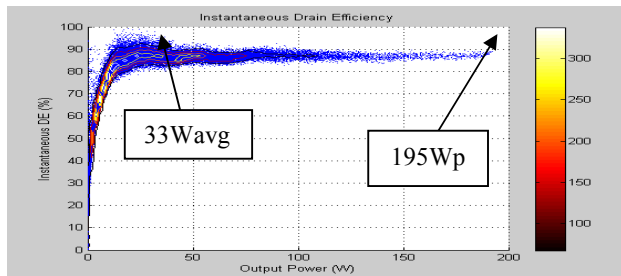

Figure 8. Measured Power vs Instantaneous Collector Efficiency, 7.7dB PAR

Figure 5 shows the measured AM-AM and AM-PM performance before pre-distortion, expressed in terms of the output signal envelope, plotted versus the corresponding instantaneous input signal envelope value recorded for a WCDMA waveform. The scatter for the different values of input power indicates a modest memory effect and phase distortion. Digital pre-distortion is effective in linearizing the characteristics. In this case, the AM-AM distortion is almost non-existent, and the AM-PM distortion is less than 10^0 p-p, which is less than Si-LDMOS and GaN transistors previously used in envelope tracking[11][12]. Fig. 6 shows the collector current I_{cc} as a function collector voltage V_{cc} at the envelope rate. The envelope load line is 4Ω average with a 1.5V intercept. The output voltage from the Vdd amplifier tracks the envelope magnitude of the RF input signal (Fig. 7) resulting in a very high collector efficiency of 85% from 7V to 29V. The output power tracks the square of the collector

voltage (Fig. 7) and results in 85% collector efficiency over a 12.5dB range, well in excess of the 6dB range for symmetric Doherty amplifiers. This performance becomes especially important for maintaining high efficiency in average power back-off. The overall improvement in output signal quality is quite apparent from the measured output spectrums as shown in Figs. 8, 9 and 10, where ACLR1&2 are improved by 12.0 dB at 5 MHz offset and 7dB at 10 MHz offset, through the memory-less digital pre-distortion. Memory mitigation results in an excellent 20dB improvement to -70dBc ACLR1&2. The ACLR specification limits for WCDMA radio base-station output signals are -45 dBc at the 5 MHz offset and -50 dBc at the 10 MHz offset, so the specifications are met with adequate margin with or without memory mitigation.

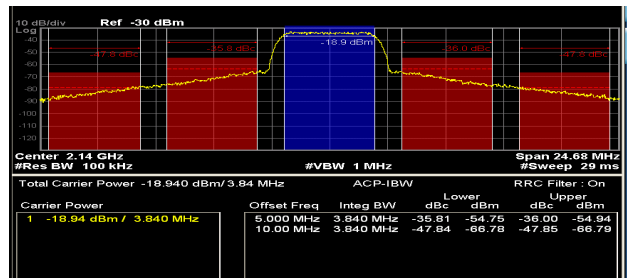

Figure 8. Normalized output power spectral density before predistortion, single carrier WCDMA 7.7dB PAR

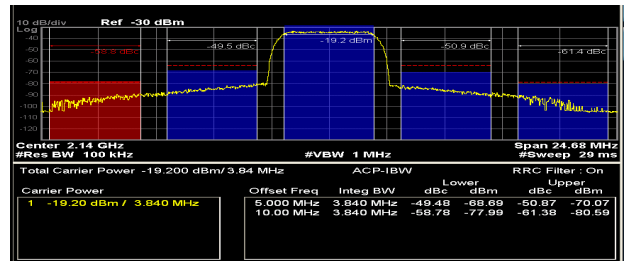

Figure 9. Normalized output power spectral density after predistortion, single carrier WCDMA 7.7dB PAR

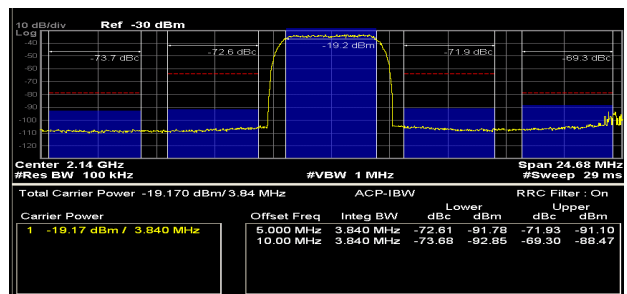

Figure 10. Normalized output power spectral density after memory mitigation, single carrier WCDMA 7.7dB PAR

Even with the adequate performance of the memoryless DPD, we applied a memory mitigation algorithm [9] to evaluate the memory effects associated with this device. The improvement of output RMS error is presented in Table 1 with an excellent final result of 0.3%.

Table 1. Summarized performance of power amplifier with single carrier WCDMA and 10MHz WiMAX signal and digital predistortion

Parameter	Gain	Po	CE	PAE	EVM	ACLR1	ACLR2
Units	dB	W	%	%	%	dBc	dBc
7.7dB PAR WCDMA	10.2	36.1	60	57	5.6	-36	-46
After ML DPD	10.2	33.2	58	55	2.9	-48	-53
After Memory DPD	10.2	33.2	58	55	0.3	-72	-70
6.6dB PAR WCDMA	10.2	44.7	63	59	5.6	-36	-46
After ML DPD	10.3	42	62	58	2.9	-49	-53
After Memory DPD	10.3	42	62	58	0.3	-70	-70
11.2dB PAR WCDMA After ML DPD	10.5	14.2	49	47	2.9	-48	-53
8.8dB PAR 10MHz WiMAX After ML DPD	10.4	25	51	48	4.9	-41	-41
After Memory DPD	10.4	25	51	48	0.7	-63	-62

CE : collector efficiency.

ML DPD: Memoryless digital predistortion

WCDMA Specifications: EVM,7%: ACLR1 < -45 dBc, ACLR2 < -50 dBc. ACLR1 at 5MHz offset, ACLR2 at 10 MHz offset for WCDMA

WiMAX Specifications: EVM<5.6% ACLR1<-25dBc,ACLR2<-32dBc

ACLR1 at 5.45MHz offset, ACLR2 at 9.75MHz offset for WiMAX

The average power added efficiency (PAE) including dissipation in the envelope amplifier is as high as 58% with average output power of 42 W after ML DPD at 6.6dB PAR. This is the highest efficiency among the reported WCDMA base-station power amplifiers [6]. The gain and error vector magnitude (EVM) are 10.2 dB and 2.9% after memoryless pre-distortion, respectively. After memory mitigation, the measured EVM drops to 0.3% and ACLR1&2 to -70 dBc at 5 MHz offset and -70 dBc at 10 MHz offset. Table 1 also summarizes the measured performance of the amplifier with 10MHz bandwidth WiMAX signal. The higher PAR of 8.8dB results in lower output power of 25W and lower PAE of 48%, but still an excellent result after ML DPD. Finally, a WCDMA signal without crest factor reduction at 11.2dB PAR was tested. The collector efficiency dropped to 49% while the output power dropped to 14.2W.

One source of the improved efficiency measured in ET amplifiers based on the HVHBT devices, relative to ET system configured with other devices, is the lower on-resistance (Ron) encountered with HVHBTs. The impact of Ron on efficiency is somewhat variable according to the amplifier design. For the representative case of Class B amplifiers driven to the edge of saturation, efficiency η is multiplied by the factor $RL/(RL+2Ron)$. We can estimate that for the present devices, RL (load resistance at output frequency) is of the order 2 Ohms, while Ron = 0.072 ohms, leading to an efficiency factor of 93%. By contrast, other

technologies transistors with comparable output power have had Ron as high as 0.2 ohms, leading to an efficiency factor of 83%[12].

VI. SUMMARY AND CONCLUSIONS

In this paper, a WCDMA WiMAX base-station power amplifier using GaAs HVHBT in envelope tracking was presented, demonstrating very high efficiency and precise output performance. Under the influence of a WCDMA source, an average efficiency of 58 % with average output power of 42W and gain of 10.2 dB was achieved with an output EVM of 0.3%. The results illustrate the potential of GaAs HVHBTs, in combination with advanced amplifier architectures, to achieve dramatic improvements in base-station power amplifiers.

REFERENCES

- [1] H. Brech, W. Brakensiek, D. Burdeaux, W. Burger, C. Dragon, G. Formicone, B. Pryor, D. Rice, "Record efficiency and gain at 2.1 GHz of high power RF transistors for cellular and 3 G base-station," 2003 IEEE IEDM, pp. 359-362, 2003
- [2] P. Kurpas, F. Brunner, R. Doerner, B. Janke, P. Heymann, A. Maasdorf, W. Doser, P. Auxemery, H. Blanck, D. Pons, J. Wuri, and W. Heinrich, "High-Voltage GaAs Power-HBTs for Base-Station Amplifier", 2001 IEEE MTT-s Dig., pp. 633-636, 2001
- [3] M. Nagahara, K. Inoue, S. Sano, H. Takahashi, and S. Takase, "A 28 V 250W GaAs power FET with high gain of 15.5 dB for W-CDMA base-stations," 2004 IEEE MTT-s Dig., pp. 983-985, 2004
- [4] K. Joshin, T. Kikkawa, H. Hayashi, T. Maniwa, S. Yokokawa, M. Yokoyama, N. Adachi, and M. Takikawa, "A 174 W high-efficiency GaN HEMT power amplifier for W-CDMA base-station applications," 2003 IEEE IEDM., pp. 633-636, 2001
- [5] W. Nagy, S. Singhal, R. Borges, J. W. Johnson, J. D. Brown, R. Therrien, A. Chaudhari, A. W. Hanson, J. Riddle, S. Booth, P. Rajagopal, E. L. Piner, K. J. Linthicum, "150 W GaN-on-Si RF Power Transistor," 2005 IEEE MTT-s Dig., WE1E, 2005
- [6] Steinbeiser, C.; Landon, T.; Suckling, C. "250W HVHBT Doherty with 57% WCDMA Efficiency Linearized to -55dBc for 2e11 6.5dB PAR"; Compound Semiconductor Integrated Circuit Symposium, 2007. CSIC 2007. IEEE 14-17 Oct. 2007 Page(s):1
- [7] F. Wang, A. Yang, D. Kimball, L. Larson, and P. Asbeck, "Design of wide bandwidth envelope tracking power amplifiers for OFDM applications," IEEE Trans. on Microwave Theory and Techniques, Vol.53, No.4, pp.1244-1255, 2005
- [8] T. Marra, D. Kimball, J. Archambault, W. Haley, and J. Thoreback, "Envelope tracking efficiency enhancement for CDMA base-station high power amplifier," IEEE Topical Workshop on Power Amplifiers for Wireless Communications, 2002.
- [9] P. Draxler, J. Deng, D. Kimball, I. Langmore, P.M. Asbeck, "Memory effect evaluation and predistortion of power amplifiers," 2005 IEEE MTT-s Dig., TH2B, 2005
- [10] G. Collinson and C. W. Suckling, "Effects of harmonic terminations on power and efficiency of GaAs HBT power amplifiers at 900 MHz", IEE Colloquium Solid-State Power Amplifiers Digest, pp. 12-1-12/5, Dec. 1991.
- [11] P. Draxler, S. Lanfranco, D. Kimball, C. Hsia, J. Jeong, J. Van de Sluis, and P.M. Asbeck, "High Efficiency Envelope Tracking LDMOS Power amplifier for W-CDMA", IEEE MTT-S Int. Microw. Symp. Dig., Jun. 2006, pp. 1534-1537.
- [12] Kimball, D.; Draxler, P.; Jeong, J.; Hsia, C.; Lanfranco, S.; Nagy, W.; Linthicum, K.; Larson, L.; Asbeck, P.; "50% PAE WCDMA base-station amplifier implemented with GaN HFETs" Compound Semiconductor Integrated Circuit Symposium, 2005. CSIC '05. IEEE 30 Oct.-2 Nov. 2005 Page(s):4 pp.